

Heros

Mono Power Amplifier

by Thrax Audio

Operating Manual

Manual issued 06/12/2023

CAUTION

THE UNIT CONTAINS NO USER SERVICEABLE PARTS. DO NOT REMOVE THE COVERS. LETHAL VOLTAGES ARE PRESENT WITHIN THE CHASSIS.

NEVER OPERATE THE AMPLIFIER WITH THE CHASSIS COVERS REMOVED.
DO NOT OPERATE THE UNIT IF WET OR NEAR WATER.

THE AMPLIFIER IS FAIRLY HEAVY. BE SURE TO USE PROPER LIFTING TECHNIQUES TO AVOID BACK STRAIN AND INJURY. BE CERTAIN TO INSTALL IT IN A SECURE LOCATION FROM WHICH IT CANNOT FALL OR TIP OVER.

WARNING: Do not allow anything to touch the tubes in normal operation - they become very hot. Take care to keep everyone, especially children and pets, from being able to reach and touch the tubes, which become extremely hot and may cause serious injury. Never touch a tube if the glass is broken. The internal structures carry high voltage and could present a serious, possibly lethal shock. If a tube breaks, unplug the amplifier and wait 30 minutes, then remove the tube. Keep flammable objects away from the amplifier.

TIME SPENT FAMILIARIZING YOURSELF WITH THIS MANUAL WILL BE WELL REWARDED.

CONTENTS

1. Important Safety Instructions	3
2. Introduction	4
3. Specifications	4
4. Unpacking and Installation	
- Unpacking	5
- Installation	5
6. Front Panel	6
7. Back Panel	
- Inputs	6
- Speaker outputs	7
- AC Fuse	7
8. Operation	8
9. Tips: Impedance Matching & Tube replacement	9

IMPORTANT SAFETY INSTRUCTIONS

READ ALL INSTRUCTIONS: All the safety and operating instructions of your Thrax Audio equipment should be read before power is applied to the equipment.

RETAIN OWNER'S MANUAL: These safety and operating instructions should be retained for future reference.

HEED WARNING: All warnings on the unit and in the operating instructions should be adhered to.

FOLLOW INSTRUCTIONS: All operating and use instructions should be followed.

CLEANING: Unplug the unit from the wall outlet and leave for at least 30 min. - make sure the unit is not hot before you start cleaning. Use dry or damp soft cloth to clean the surfaces. Do not use sprays, corrosive or abrasive cleaning products.

VENTILATION: Do not block any ventilation openings. Do not install near any heat sources such as radiators, heat registers, stoves, or other apparatus (including amplifiers). The unit should not be installed in a built-in location such as a bookcase or rack unless proper ventilation is provided.

GROUNDING: Do not defeat the safety purpose of the grounding-type plug. A grounding-type plug has two blades and a third grounding prong. The third prong is provided for your safety. If the provided plug does not fit into your outlet, consult an electrician for replacement of the obsolete outlet.

POWER CORD PROTECTION: Protect the power cord from being walked on or pinched particularly at plugs, convenience receptacles and the point where they exit from the apparatus.

LIGHTNING: Unplug this apparatus during lightning storms or when unused for long periods of time.

SERVICING: Refer all servicing to qualified service personnel. Servicing is required when the apparatus has been damaged in any way, such as if the power-supply cord or plug is damaged, liquid has been spilled inside the appliance or it has been exposed to moisture, the appliance does not operate normally, or has been dropped.

DO NOT OPEN THE CABINET: There are no user serviceable components inside this product. Opening the cabinet may present a shock hazard, and any modification to the product will void your warranty.

WARNING: To reduce the risk of fire or electric shock, do not expose this apparatus to rain or moisture.

INTRODUCTION

The Heros mono power amplifier is a top-end audio amplifier and a unique component. Its unusual topology, premium parts, and flexibility make it a pleasure to hear and operate. Heros is a two-stage hybrid power amplifier – tube input stage and solid state output stage with transformer loaded output.

Features

2 inputs – one unbalanced on RCA and one balanced on XLR

Amplification level switch – low and high

Speaker impedance switch - 4 Ohm / 8 Ohm

Inside you get

Separate constant current PSU for the input tube – 6N6P and separate PSU for the output stage. The input/driver stage is a differential triode stage with grounded cathodes. The output stage is a pair of Power J-FET transistors operating in a push-pull output transformer.

The case is made from plates of machined solid aircraft grade aluminium.

SPECIFICATIONS

- Inputs
 - 1 unbalanced RCA connector
 - 1 balanced XLR connector
- Output 100W in 4Ω/8Ω
- Power supply 115 or 230 V
- Power consumption 230W
- Dimensions 230W x 400D x 340H mm
- Weight 35Kg
- Finish Black or Silver anodized aluminum
- Tube compliment :
 - 1x 6N6P amplification

UNPACKING AND INSTALLATION

Unpacking

The Heros is shipped with the vacuum tube installed. Unpack carefully, keep in mind Heros weighs 30 kg ! All Thrax Audio shipping boxes have been specially designed to protect their contents and special care has been taken to prevent damage under normal shipping conditions. Mishandling should be evident upon inspection of the shipping container. Carefully remove your new component from its packing and examine it closely for signs of shipping damage. We strongly recommend saving all original packing to protect your component from damage should you wish to store it or ship it at a later date.

Installation

- Provide adequate ventilation. Do not operate on carpet or any other surface that might block air flow. The chassis will become warm in normal use!
- Do not allow the chassis to touch any metal parts, such as the frame of an equipment rack. This might create a parallel ground path that could degrade the sound of your system.
- Input connection is via single ended RCA jacks or XLR jacks (which can be from balanced or unbalanced sources).
- Connect the input and speaker cables.
- Connect the power cable from the power supply to the power amplifier.
- Connect the power supply to the power source indicated on the voltage selector card (visible by the main fuse), either 115 or 230 volts AC. You may select what voltage to use by means of the removable selector card located behind the fuse in the power connectors. Remove the card and reinstall so that the desired voltage may be read; be certain to change the fuse to the correct value. Connect the power supply to the power source indicated on the rear panel. Avoid power conditioners that float the ground pin. ALWAYS connect power cord to component before plugging it into an AC outlet, and make sure that unit's power switch is set to the "OFF" position before making the final connection. For best performance, try to route the power cord away from signal cables.
- Power requirements are approximately 230 watts per channel. Pay close attention to power quality, and be aware that different power cords can alter the sound.
- Set the output impedance switch to either "4 ohm" or "8 ohm" to suit your loudspeaker. Connect the speaker cables: the black lead goes to "-", the red lead goes to "+". For further information see Tips : Impedance Matching.
- Set the input type switch to XLR or RCA, to match the source and cables.

WARNING: Do not allow anything to touch the tubes in normal operation - they become very hot. Take care to keep everyone, especially children and pets, from being able to reach and touch the tubes, which become extremely hot and may cause serious injury. Never touch a tube if the glass is broken. The internal structures carry high voltage and could present a serious, possibly lethal shock. If a tube breaks, unplug the amplifier and wait 30 minutes, then remove the tube. Keep flammable objects away from the amplifier.

FRONT PANEL

"ON/OFF" Button

Switches the unit on and off. See OPERATION SECTION for details.

LED Indicator

Red light indicates stand-by mode, green light – operation mode. Green light flashes during warm-up time.

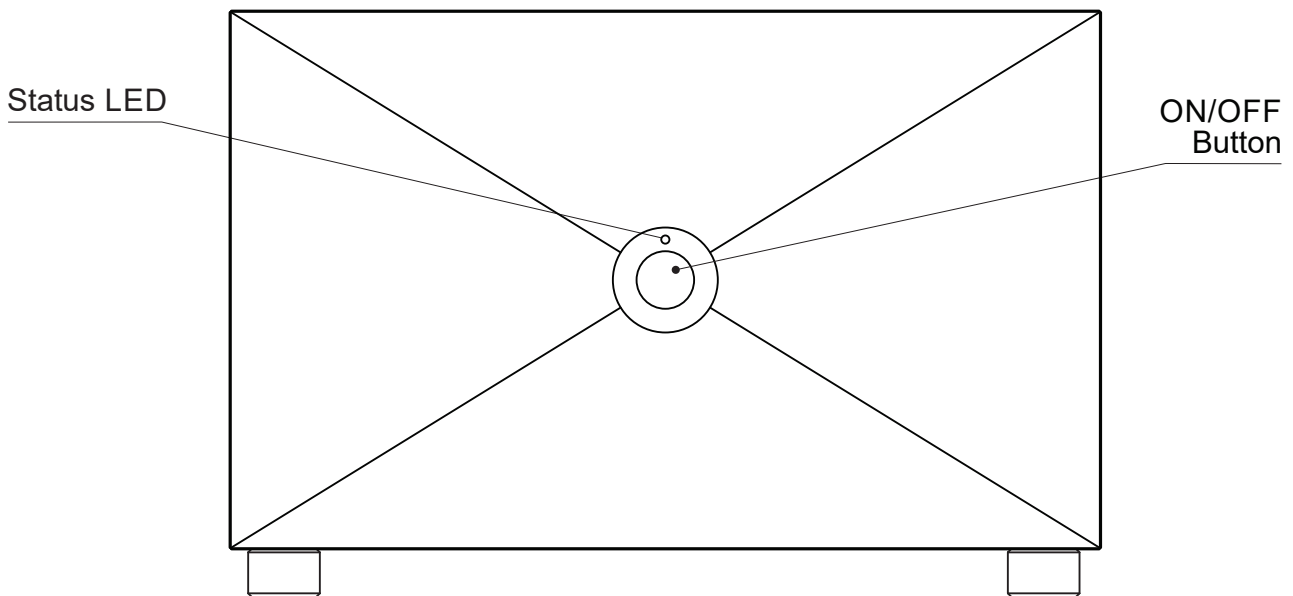

BACK PANEL

Inputs

A XLR jack is provided for balanced connection to a pre-amplifier. The "INPUT SELECT" switch should be set to the "XLR" (left) position.

RCA (single-ended) connection normally is made to the RCA jack. The "INPUT SELECT" switch is set to "RCA" (right) position.

NOTE: Do not remove and connect input cables or speaker cables while the amplifier is running. Doing so you risk damaging your loudspeakers or amplifier.

Do not operate the amplifier without a loudspeaker.

Input select switch

Switches between XLR / RCA inputs

BACK PANEL

Gain switch

Low / High positions to select the gain suitable to your audio system

Speaker impedance switch

4 Ohm / 8Ohm - Use this to select the output impedance

Speaker output

The speaker cables connect to the Speaker Connectors. Either banana jacks, bare wires or spade plugs can be used. If bare wire is used, be careful that no stray strands get loose that could cause a short-circuit. The "Common" or "Ground" lead connects to the black jack. The "Hot" lead goes to the red jacks. Bare wires and spade plugs must be tightened by rotating the ratchet screw clockwise.

A/C Fuses and Mains switch

There are fuses located in the IEC power connector on the back panel. For 220 volt operation 4 amperes "slow blow" fuses are used. For 110 volt operation the fuses should be 8 amperes. If power does not come on, contact your authorized service representative or consult the factory for more information.

Trigger In

Using the Trigger In function will turn the amplifier on automatically when it receives a signal, and turn it off when there's no signal.

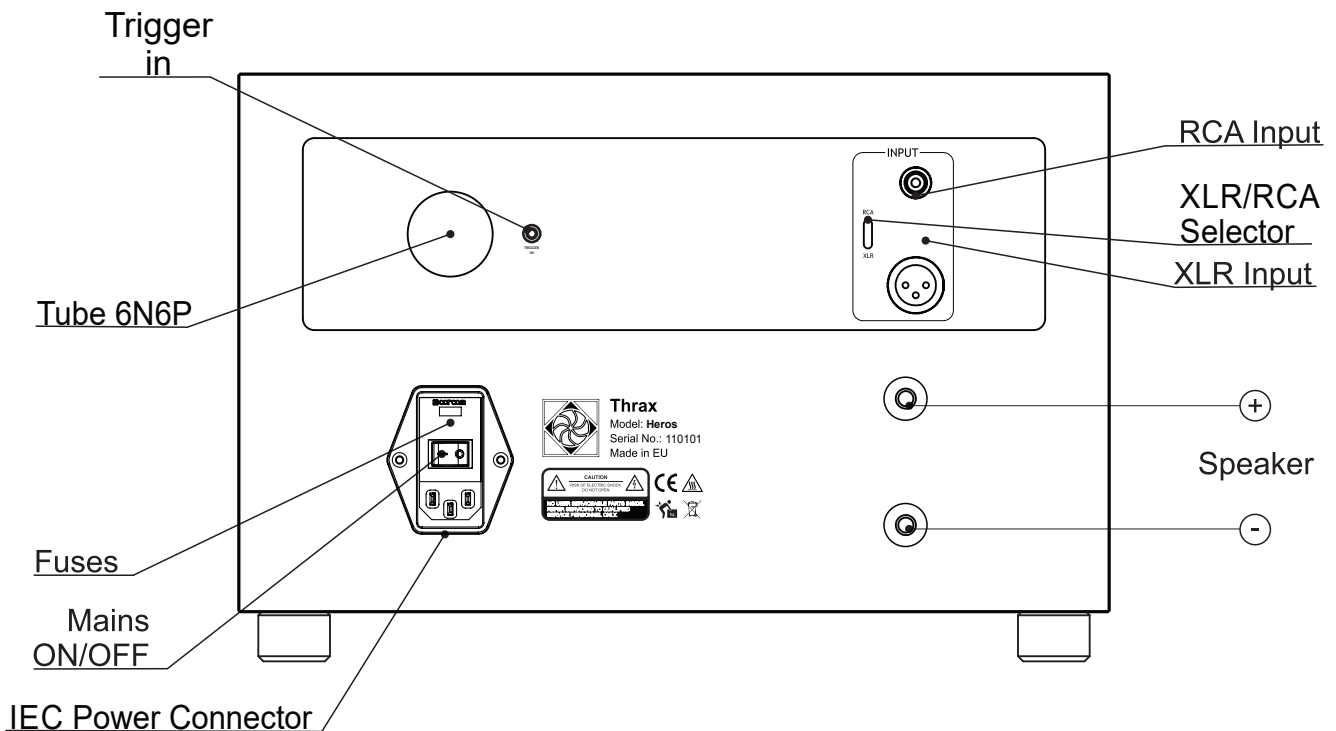

OPERATION

For initial power up press the main switch located on the back panel. The LED on the front panel lights red indicating the unit is now in stand by mode.

To switch the power amplifier on press the "ON/OFF" button located on the front panel. The LED indicator flashes green whilst warming up for about 2 minutes and turns to solid green when your Heros is ready for use.

To turn the power amplifier off press the "ON/OFF" button. However if you are not going to use the amplifier for a long period we recommend turning it off using the power switch on the back panel to save power.

We recommend switching your audio system on in the following manner: the sources first, then the preamplifiers, processors and lastly - the power amplifier. When switching off go backwards – start with the power amp and finish with the sources.

As with all high-fidelity products, the sound characteristic changes somewhat as it warms up. Best sound will be achieved after about 15 minutes of operation.

Any time that the Heros power amplifier has not been used for a few weeks the sound may be different. This is also normal for high resolution audio equipment. Optimum sound should return after a few hours of operation, preferably with an audio signal.

Note that although your Thrax Audio System has been run for 72 hours at the factory, it will continue to "break in" for approximately 150 hours. Also be aware that many components display the need for a new break in period after being transported in unheated cargo aircraft.

Impedance Matching

The available impedance settings on your Heros are:

- 8 ohms – use for speakers rated 6 to 16 ohms
- 4 ohms - use for speakers rated 2 to 6 ohms

Since the impedance of most loudspeakers varies over a wide range, experimentation is essential. Most speakers have a rated impedance of 4 or 8 ohms. We recommend starting with the 8 ohm connection; after you know what it sounds like, try the 4 ohm connection. Choose the one that sounds best to your ears.

Tube replacement

Your Heros comes with the tube pre-installed. A 6N6P tube's working time is approximately 2000 hours. When tube replacement is due, we strongly advise you to order replacement tubes from your Thrax Audio dealers, before the sound quality starts to deteriorate.

Before replacing the tube, all power must be turned off. Unplug the power cord from the wall, and remove all audio interconnect cables. Wait 15 minutes before removing the tube.

When removing the tube, handle it carefully, with minimum twists.

Install the new tube firmly in the socket, noting the location of holes in the socket and pins of the tube, making sure its pin pattern corresponds to the holes in the tube socket.

