

# Maximinus MkII

## Audio DAC

by Thrax Audio

## Operating Manual

Manual issued xx/03/2020

### CAUTION

THE UNIT CONTAINS NO USER SERVICEABLE PARTS. DO NOT REMOVE THE COVERS. LETHAL VOLTAGES ARE PRESENT WITHIN THE CHASSIS.

NEVER OPERATE THE DAC WITH THE CHASSIS COVERS REMOVED.  
DO NOT OPERATE THE UNIT IF WET OR NEAR WATER.

THE DAC IS FAIRLY HEAVY. BE SURE TO USE PROPER LIFTING TECHNIQUES TO AVOID BACK STRAIN AND INJURY. BE CERTAIN TO INSTALL IT IN A SECURE LOCATION FROM WHICH IT CAN NOT FALL OR TIP OVER.

TIME SPENT FAMILIARIZING YOURSELF WITH THIS MANUAL WILL BE WELL REWARDED.

# CONTENTS

- 1. Important Safety Instructions ..... 3
- 2. Introduction ..... 4
- 3. Specifications ..... 4
- 4. Unpacking and Installation
  - Unpacking ..... 5
  - Installation ..... 5
- 5. Front Panel ..... 6
- 6. Back Panel
  - Inputs ..... 7
  - Outputs ..... 7
  - Power Connector, Main Switch, Fuses, Input Voltage Selector .. 7
- 7. Operation ..... 8

## IMPORTANT SAFETY INSTRUCTIONS

**READ ALL INSTRUCTIONS:** All the safety and operating instructions of your Thrax Audio equipment should be read before power is applied to the equipment.

**RETAIN OWNER'S MANUAL:** These safety and operating instructions should be retained for future reference.

**HEED WARNING:** All warnings on the unit and in the operating instructions should be adhered to.

**FOLLOW INSTRUCTIONS:** All operating and use instructions should be followed.

**CLEANING:** Unplug the unit from the wall outlet before cleaning.

**VENTILATION:** Do not install near any heat sources such as radiators, heat registers, stoves, or other devices (including amplifiers). The unit should not be installed in a built-in location such as a bookcase or rack unless proper ventilation is provided.

**GROUNDING:** Do not defeat the safety purpose of the grounding-type plug. A grounding-type plug has two blades and a third grounding prong. The third prong is provided for your safety. If the provided plug does not fit into your outlet, consult an electrician for replacement of the obsolete outlet.

**POWER CORD PROTECTION:** Protect the power cord from being walked on or pinched particularly at plugs, convenience receptacles and the point where they exit from the unit.

**LIGHTNING:** Unplug this unit during lightning storms or when unused for long period of time.

**SERVICING:** Refer all servicing to qualified service personnel. Servicing is required when the unit has been damaged in any way, such as if the power-supply cord or plug is damaged, liquid has been spilled inside the appliance or it has been exposed to moisture, the appliance does not operate normally, or has been dropped.

**DO NOT OPEN THE CABINET:** There are no user serviceable components inside this product. Opening the cabinet may present a shock hazard and any modification to the product will void your warranty.

**WARNING:** To reduce the risk of fire or electric shock, do not expose this unit to rain or moisture.

## INTRODUCTION

The Maximinus is a universal DAC with some advanced DSP functions supporting up to 32bit/384kHz audio data rates.

### Features

- Versatile I/O:           7 digital inputs covering all popular interface formats  
                                  Two sets of analogue outputs - RCA and XLR
- The DSP functions: Dithering - improves sound quality when downsampling is necessary  
                                  De-emphasis - for playback of pre-emphasized recordings  
                                  Selection of four digital filters with different impulse response
- EMI/RFI protection: Transformer decoupled I/O and power supplies  
                                  True balanced interface

## SPECIFICATIONS

- Inputs
  - 2x COAX (RCA) connectors. Limited to 384 kHz, 24 bit data
  - 2x AES/EBU (XLR) connectors
  - 2x TOSLINK (optic) connectors. This format has limited bandwidth and works for maximum sample rates of 192 kHz
  - 1 x USB (optional)
  - Bluetooth connectivity
- Output
  - 1 pair unbalanced RCA connectors
  - 1 pair balanced XLR connectors
- Power supply ..... 115 or 230 V
- Power consumption ..... 30W
- Dimensions ..... WxDxH - 432x400x120 mm
- Weight ..... 12Kg
- Finish ..... Black or Silver anodized aluminium

## UNPACKING AND INSTALLATION

This section describes the unpacking and installation procedures for your new component.

### Unpacking

All Thrax Audio shipping boxes have been specially designed to protect their contents and special care has been taken to prevent damage under normal shipping conditions. Mishandling should be evident upon inspection of the shipping container. Carefully remove your new component from its packing and examine it closely for signs of shipping damage. We strongly recommend saving all original packing to protect your component from damage should you wish to store it or ship it at a later date.

### Installation

- BE CERTAIN TO INSTALL THE UNIT IN A SECURE LOCATION FROM WHICH IT CANNOT FALL OR TIP OVER
- Provide adequate ventilation - the chassis will become warm in normal use. Do not operate on carpet or any other surface that might block air flow
- Do not allow the chassis to touch any metal parts, such as the frame of an equipment rack. This might create a parallel ground path that could degrade the sound of your system
- Connect the input and output cables. Input connection is via COAX , AES/EBU TOSLINK or USB. Output can be via RCA or XLR jacks

**IMPORTANT:** READ THE SECTIONS "BACK PANEL"

**WARNING:** The unit should be operated only at rated voltage, indicated on the power connector. If you are not sure what is the mains voltage supplied to your home, consult with your unit dealer.

Connect the power supply to the power source indicated on the rear panel. Avoid power conditioners that float the ground pin. ALWAYS connect power cord to component before plugging it into an AC outlet, and make sure that unit's main switch is set to the „off" position before making the final connection. For best performance, try to route the power cord away from signal cables.

Pay close attention to power quality, and be aware that different power cords can alter the sound.

## FRONT PANEL

### “Power On/Off” Button:

Switches the unit ON and OFF.

### “Filter” Button:

This button toggles between 4 digital filters - Slow, SD Slow, Sharp, SD Sharp, and the Bypass option.

### “Mute” Button:

Press to Mute/Unmute device.

### “Menu” Button:

Press the Menu Button to access the Menu or to navigate one step back.

### Control Knob:

Turn the knob to Select an Input, navigate through the Menu, and press it to Select a highlighted option in the Menu.

### TFT LCD Display

Shows the selected input, the active DSP functions and the menu options. This display is auto dimmable – turns off in few seconds if no control is operated. It turns on automatically at power up, in case the input signal changes or user menu is selected.

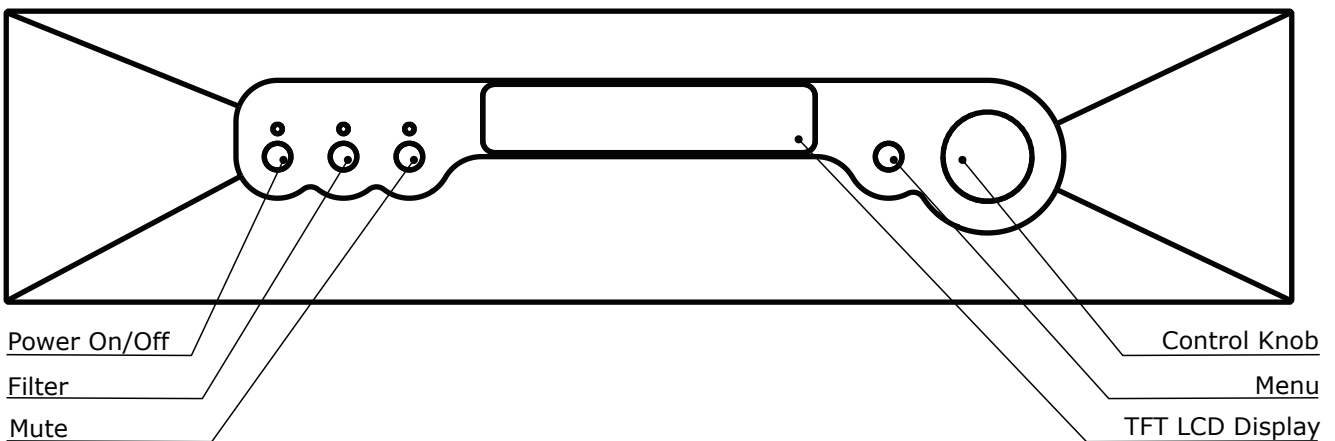

Fig. 1

## BACK PANEL

### IEC Power Connector, Main Switch, Fuses and Input Voltage Selector:

There are fuses located in the IEC power connector on the back panel. For 230 volts operation a 0.63 amperes "Slow Blow" fuse is used. For 115 volts operation the fuse should be 1.25 amperes. If power does not come on, contact your authorized service representative.

### Inputs:

2 x COAX jacks, labeled 1 and 2, accommodate signal from digital sources, good for short runs and lower frequencies

2 x TOSLINK inputs, labeled OPT 1 and OPT 2, provide ground isolation between the units and noise immunity over long runs

2 x AES/EBU inputs, labeled AES 1 and AES 2 to accommodate high quality signal, that uses professional protocol

1 x USB input (optional)

Currently a USB – input is available to accommodate digital signal from a computer source

### Outputs:

Two sets of analog output jacks are provided – a pair single-ended RCA outputs and a pair of balanced XLR outputs.

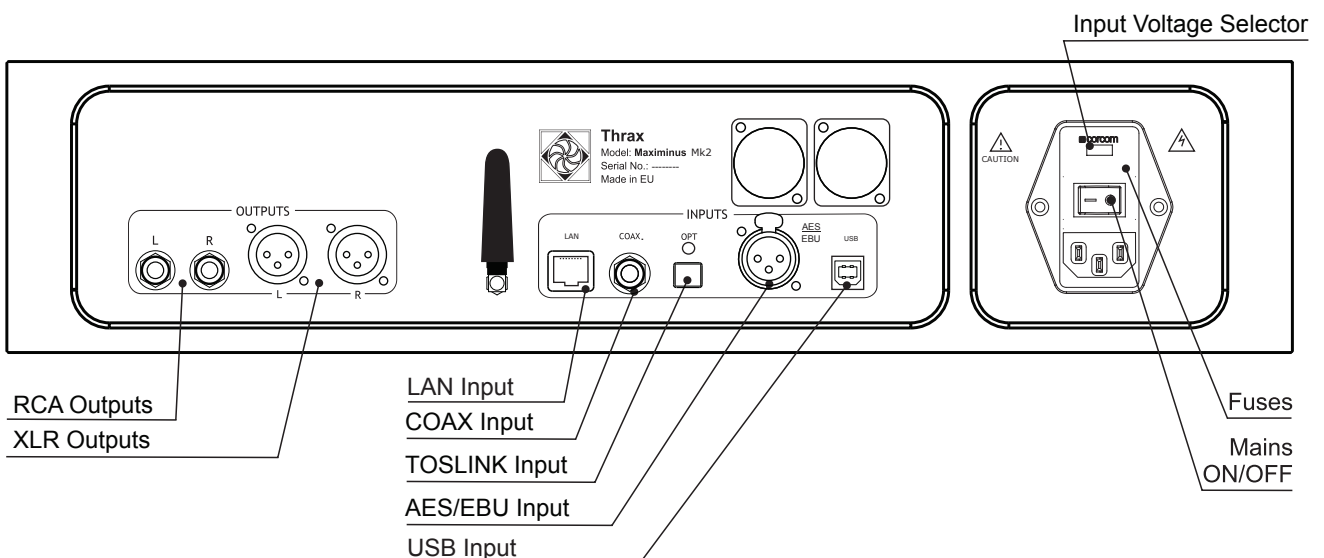

Fig. 2

## OPERATION

To switch the DAC on press the "ON/OFF" button on the front panel. The red standby indicator blinks green for approx 4 sec. whilst the unit warms up. When ready, the indicator will stop blinking, and the last active source will be selected automatically.

The screen will display the selected input, and the active DSP functions.

As with all high fidelity products, the sound characteristic changes somewhat as it warms up. Best sound will be achieved after about 15 minutes of operation.

Any time that the Maximinus DAC has not been used for a few weeks the sound may be different. This is also normal for high resolution audio equipment. Optimum sound should return after a few hours of operation, preferably with an audio signal.

Note that although your Thrax Audio System has been run for 72 hours at the factory, it will continue to "break in" for approximately 150 hours. Also be aware that many components display the need for a new break in period after being transported in unheated cargo aircraft.

### Digital Filters

The four main types of Digital Filters on the Maximinus DAC are easily accessible with the Filter button on the front panel. Dithering and De-emphasis functions are controlled from the Menu.

The digital filter is necessary because mirrored image frequencies created during the conversion process must be removed. If the DAC did not have a digital filter, an analog filter with an aggressive response must remove these image frequencies. Analog filters seriously damage the signal by corrupting the original phase of the sound and cannot fully remove the high frequency images. This results in harsh or rolled off high frequencies and poor soundstage focus.

Our DAC offers a choice of 6 digital filters (Slow, Sharp, SD Slow, SD Sharp, Dithering and Deemphasis). Each option provides a distinct, glorious listening experience. You may favor one or the other, or enjoy changing the filter response to suit the music you listen to.

### Menu structure

1. Timer - set the timer to turn the Maximinus off automatically after a certain amount of time (30, 60, 90, 120, 180 minutes)
2. Display - adjust the display brightness
3. Dimming - dims the screen when unused (options of 10s, 20s, 30s, 45s or 1 minute)
4. Date - set the current date
5. Clock - set the current time



## OPERATION

6. Remote - customize the buttons on your remote. Using knob on the front panel, navigate to highlight the command you would like to assign to a button on your remote and hold that button for 5 seconds. To dismiss a button assignment, press the Filter 2 button while the command is highlighted in the Remote Menu.

7. About - displays the firmware information for 7 seconds.

8. Filter - controls the Dithering and De-emphasis filters.

9. Output - select XLR or RCA to select the active output.

### Input Selection

Turn the Control Knob to select your desired input.

To turn off the DAC press the ON/OFF button. All the unit circuitry will be turned off for minimum power consumption leaving only a small STANDBY circuit running. However, if you are not going to use the DAC for a long period we recommend turning it off, using the power switch on the back panel, to save power.

